

# \*TB 9-6670-258-24

DEPARTMENT OF THE ARMY TECHNICAL BULLETIN

## CALIBRATION PROCEDURE FOR AIRCRAFT WEIGHING KIT, BLH, MODEL C1; EVERGREEN, MODEL ROADRUNNER II; AND REVERE, MODELS C7500, C46500, C55800-4-25, C55800-3-50, CS7, 155800-00, 155800-01, AND 155800-03

Headquarters, Department of the Army, Washington, DC  
18 September 2008

*Distribution Statement A: Approved for public release; distribution is unlimited.*

### REPORTING OF ERRORS AND RECOMMENDING IMPROVEMENTS

You can improve this manual. If you find any mistakes or if you know of a way to improve these procedures, please let us know. Mail your letter or DA Form 2028 (Recommended Changes to Publications and Blank Forms) directly to: Commander, U.S. Army Aviation and Missile Command, ATTN: AMSAM-MMC-MA-NP, Redstone Arsenal, AL 35898-5000. A reply will be furnished to you. You may also send in your comments electronically to our E-mail address: [2028@redstone.army.mil](mailto:2028@redstone.army.mil) or by fax 256-842-6546/DSN 788-6546. For the World Wide Web use: <https://amcom2028.redstone.army.mil>. Instructions for sending an electronic 2028 can be found at the back of this manual.

SECTION		Paragraph	Page
I.	IDENTIFICATION AND DESCRIPTION		
	Test instrument identification .....	1	2
	Forms, records, and reports.....	2	2
	Calibration description .....	3	2
II.	EQUIPMENT REQUIREMENTS		
	Equipment required.....	4	3
	Accessories required.....	5	3
III.	CALIBRATION PROCESS FOR BLH, MODEL C1; AND REVERE, MODELS C46500, C55800-4-25, C7500, CS7, AND ROADRUNNER II		
	Preliminary instructions .....	6	3
	Equipment setup.....	7	4
	System calibration .....	8	6

\*This bulletin supersedes TB 9-6670-258-35, dated 5 May 2005.

	Paragraph	Page
System calibration alternate technique (reference).....	9	9
Final procedure .....	10	13
IV. CALIBRATION PROCESS FOR REVERE, MODELS C55800-3-50, 155800-00, 155800-01, AND 155800-03		
Preliminary instructions .....	11	14
Equipment setup.....	12	14
Load test .....	13	15
Zero and phase check alternate technique (reference).....	14	17
Load test alternate technique (reference)	15	18
Final procedure .....	16	20

## SECTION I IDENTIFICATION AND DESCRIPTION

**1. Test Instrument Identification.** This bulletin provides instructions for the calibration of Aircraft Weighing Kit, BLH, Model C1; Evergreen, Model Roadrunner II; and Revere, Models C7500, C46500, C55800-4-25, C55800-3-50, CS7, 155800-00, 155800-01, and 155800-03. The manufacturers' manuals were used as the prime data sources in compiling these instructions. The equipment being calibrated will be referred to as the TI (test instrument) throughout this bulletin.

**a. Model Variations.** Variations among models are described in text.

**b. Time and Technique.** The time required for this calibration is approximately 3 hours, using the physical technique.

### 2. Forms, Records, and Reports

**a.** Forms, records, and reports required for calibration personnel at all levels are prescribed by TB 750-25.

**b.** Adjustments to be reported are designated (R) at the end of the sentence in which they appear. When adjustments are in tables the (R) follows the designated adjustment. Report only those adjustments made and designated with (R).

**3. Calibration Description.** TI parameters and performance specifications which pertain to this calibration are listed in table 1.

Table 1. Calibration Description

Test instrument parameters	Performance specifications
Force	Range: 0 to 50,000 lbs (3 cells) <sup>1</sup> Accuracy: ±0.25% of reading or 25 lbs, whichever is greater (±25 lbs from 0 to 10,000 lbs)

<sup>1</sup>Procedure limitation. Three load cells (50,000 lbs each) calibrated only from 0 to 15,000 lbs. Alternate technique (reference) covers complete range of 50,000 lbs.

## SECTION II EQUIPMENT REQUIREMENTS

**4. Equipment Required.** Table 2 identifies the specific equipment to be used in this calibration procedure. This equipment is issued with Secondary Transfer Calibration Standards Set AN/GSM-287 or AN/GSM-705 and Secondary Reference Calibration Standards Set NSN 4931-00-621-7878. Alternate items may be used by the calibrating activity. The items selected must be verified to perform satisfactorily prior to use and must bear evidence of current calibration. The equipment must meet or exceed the minimum use specifications listed in table 2. The accuracies listed in table 2 provide a four-to-one ratio between the standard and TI. Where the four-to-one ratio cannot be met, the actual accuracy of the equipment selected is shown in parenthesis.

**5. Accessories Required.** The accessories required for this calibration are common usage accessories, issued as indicated in paragraph 4 above, and are not listed in this calibration procedure. The following peculiar accessory is also required for this calibration: Lower adapter, fabricated, (figure 6) to be used when performing alternate reference technique.

Table 2. Minimum Specifications of Equipment Required

Common name	Minimum use specifications	Manufacturer and model (part number)
LOAD CELL NO. 1 <sup>1</sup>	Range: 0 to 2025 lbs Accuracy: $\pm 0.0625\%$ (0.1%)	Revere Corp., Model USP1-2B (MIS-26331TY1)
LOAD CELL NO. 2 <sup>1</sup>	Range: 0 to 5025 lbs Accuracy: $\pm 0.0625\%$ (0.1%)	Revere Corp., Model USP1-5B (MIS-26331TY2)
LOAD CELL NO. 3 <sup>1</sup>	Range: 0 to 15,037.5 lbs Accuracy: $\pm 0.0625\%$ (0.1%)	Revere Corp., Model USP1-20B (MIS-26331 TY3)
LOAD CELL NO. 4 <sup>1, 2</sup>	Range: 0 to 50,125 lbs Accuracy: $\pm 0.0625\%$ (0.1%)	Toroid Corp., Model 35-133BCF60K (MIS-26331TY4)
LOAD CELL INDICATOR	Range: 0 to 12,000 counts Accuracy: $\pm 0.01\%$ FS	Force Torque Indicator, MGCPLUS, (13589298)
MULTIMETER	Measurement capability: 24 V dc	Fluke, Model 8840A/AF05 (AN/GSM-64D)
OSCILLOSCOPE	Range: 1.50 V p-p Accuracy: $\pm 3\%$	(OS-303/G)

<sup>1</sup>Limited deployed item at transfer.

<sup>2</sup>To be used when performing alternate reference technique.

## SECTION III CALIBRATION PROCESS FOR BLH, MODEL C1; AND REVERE, MODELS C46500, C55800-4-25, C7500, CS7, AND ROADRUNNER II

### 6. Preliminary Instructions

a. The instructions outlined in paragraphs 6 and 7 are preparatory to the calibration process. Personnel should become familiar with the entire bulletin before beginning the calibration.

**b.** Items of equipment used in this procedure are referenced within the text by common name as listed in table 2.

**c.** Unless otherwise specified, verify the result of each test and, whenever the test requirement is not met, take corrective action before continuing with the calibration. Adjustments required to calibrate the TI are included in this procedure. Additional maintenance information is contained in the manufacturers' manuals for this TI.

**d.** Unless otherwise specified, all controls and control settings refer to the TI.

**NOTE**

Units having transfer equipment will use the transfer technique. If calibration above 15,000 pounds is required, the reference technique will be utilized. If transfer equipment is not available, use reference technique pending availability of transfer equipment. All TI's certified by transfer technique will have a DA Label 163 affixed stating that each cell was certified to 15,000 pounds only. When transfer technique is used and TI cannot be adjusted to within tolerance, TI will be forwarded for reference calibration and repair.

**7. Equipment Setup**

**WARNING**

HIGH VOLTAGE is used or exposed during the performance of this calibration. DEATH ON CONTACT may result if personnel fail to observe safety precautions. REDUCE OUTPUT(S) to minimum after each step within the performance check where applicable.

**a.** Set voltage selector switch on TI to position which corresponds to power source being used. Connect TI to power source.

**b.** If ac voltage is used, check voltage as follows:

(1) Set power switch to 115 V, 60 Hz.

(2) Operate **BATTERY VOLTAGE** switch on indicator panel of TI and adjust **AC VOLTAGE ADJUST** control until pointer of balance meter indicates in green area of milliammeter scale.

**c.** If 24 V dc is used as power source, operate **BATTERY VOLTAGE** switch and check polarity. If meter indication is in yellow area, change leads and operate **BATTERY VOLTAGE** switch again. If meter indication is in red area, battery voltage is either too high or too low and should be replaced.

**d.** Setup equipment as shown in figure 1 using load cell No. 2 and TI cell No. 1.

**e.** Connect all three TI cells to TI indicator using proper cables (color coded).

**NOTE**

Do not disconnect TI cells from TI indicator except as necessary when making setups.

- f. Connect cable to appropriate connectors on load cell No. 2 and load cell indicator.
- g. Connect load cell indicator to a 115 V ac power source. Energize all equipment and allow unit to warm-up for 15 minutes.

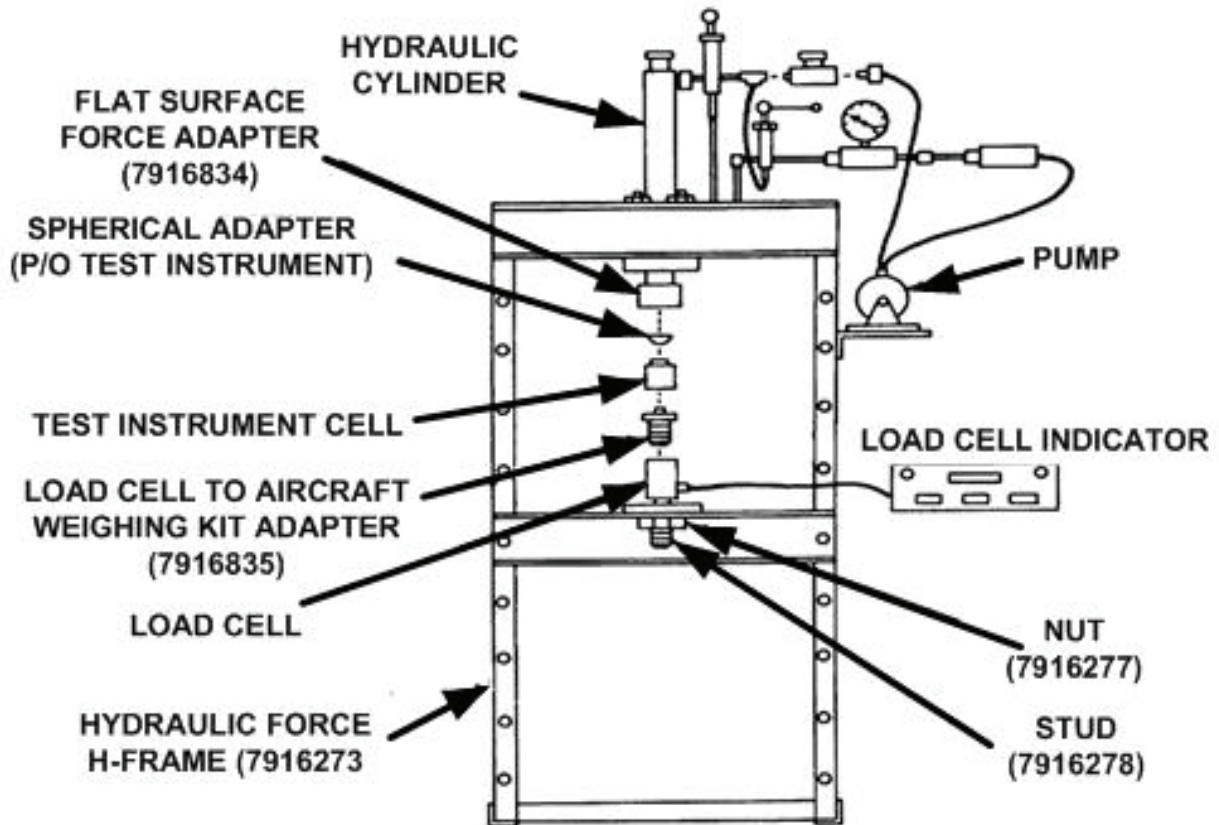

Figure 1. Aircraft weighing kit - equipment setup.

- h. Set TI **CELL BALANCE** switch to **ON** and **CELL SELECTOR** switch to **1**.
- i. Set TI **WEIGHT** dial and **INITIAL LOAD** switch to **0**.
- j. Adjust TI **ZERO SET** control No. 1 for balance in no load condition.
- k. Set TI **INITIAL LOAD** switch to **5000** (15,000 pounds, using load cell No. 3) and **WEIGHT** dial to **0** pounds.
- l. Exercise load cell and TI cell as described in (1) through (5) below:
  - (1) Apply force slowly to load cell and TI cell to obtain approximately 5000 pounds (15,000 pounds, load cell No. 3).

- (2) Release force to obtain a zero indication on indicators.
- (3) Repeat (1) and (2) above two more times.
- (4) Set **INITIAL LOAD** switch to **0** and verify that TI indicator indicates **0**.
- (5) Readjust load cell indicator **BRIDGE-ZERO**, if necessary, to obtain a reading of **0 0000**.

**8. System Calibration**

**a. Performance Check**

- (1) Set TI **INITIAL LOAD** switch to **0** and adjust **WEIGHT** dial to 500 pounds.

**NOTE**

For Roadrunner II models with 15K load cell, do not certify below 1000 pounds.

- (2) Apply force from hydraulic force H frame for null indication on TI balance meter. If indication on load cell indicator is not between 475 and 525, perform **b** below.

**NOTE**

Do not overshoot null condition. If this occurs, remove force and repeat **a** (2) above.

- (3) Repeat (1) and (2) above for **INITIAL LOAD** switch and **WEIGHT** dial settings listed in table 3. Load cell indicator will indicate within limits specified.

Table 3. Dc Voltage

INITIAL LOAD switch settings	WEIGHT dial settings	Total force	Load cell indicator indications	
			Min	Max
0	2050	2050	2025	2075
0	2200	2200	2175	2225
0	2500	2500	2475	2525
0	5000	5000	4975	5025
5000	0	5000	4975	5025
5000 <sup>1</sup>	1000	6000	5975	6025
5000	2000	7000	6975	7025
5000	3000	8000	7975	8025
5000	4000	9000	8975	9025
5000	5000	10,000	9975	10,025
10,000	0	10,000	9975	10,025
10,000	5000	15,000	14,962.5	15,037.5
15,000	0	15,000	14,962.5	15,037.5

<sup>1</sup>Replace load cell No. 2 with load cell No. 3 and repeat technique of 7 j through l above.

- (4) Release force from system and remove TI cell No. 1.
- (5) Repeat 7 e, j through l, and 8 a (1) through (3) above for each of the remaining two TI cells.

## b. Adjustments

### NOTE

For Roadrunner II adjustment, perform step (13) through (17) below only.

- (1) Connect multimeter to gray (+) and violet (-) terminals of TI power supply switch.
- (2) Adjust R201 (fig. 2) for 24 V dc as indicated on multimeter.

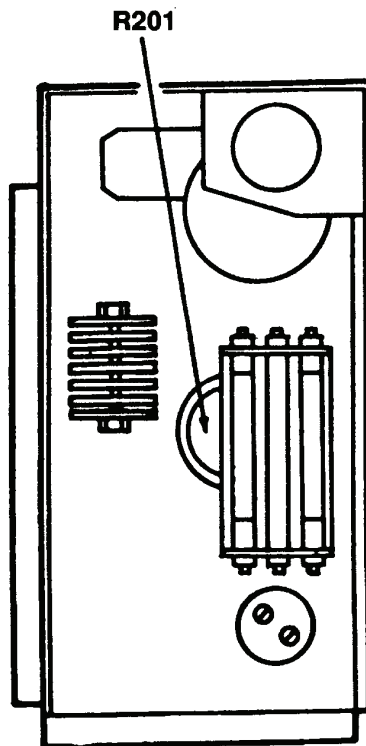

Figure 2. Weighing kit power supply - rear view.

- (3) Zero adjust TI cell under test in a no load condition.
- (4) Apply a known load to system, preferably 15,000 pounds.
- (5) Set TI **INITIAL LOAD** switch and adjust **WEIGHT** dial of indicator amplifier assembly to amount of load applied.
- (6) Adjust appropriate TRIM POT (span) (fig. 3) until indicator pointer of TI indicates a null. A trim pot is provided for each cell. (R)

### NOTE

In older models of TI, no span adjustment can be made. Resistors of the proper value must be installed. If this becomes necessary, install adjustable resistors of proper nominal value and repeat **b** (3) through (6) above.

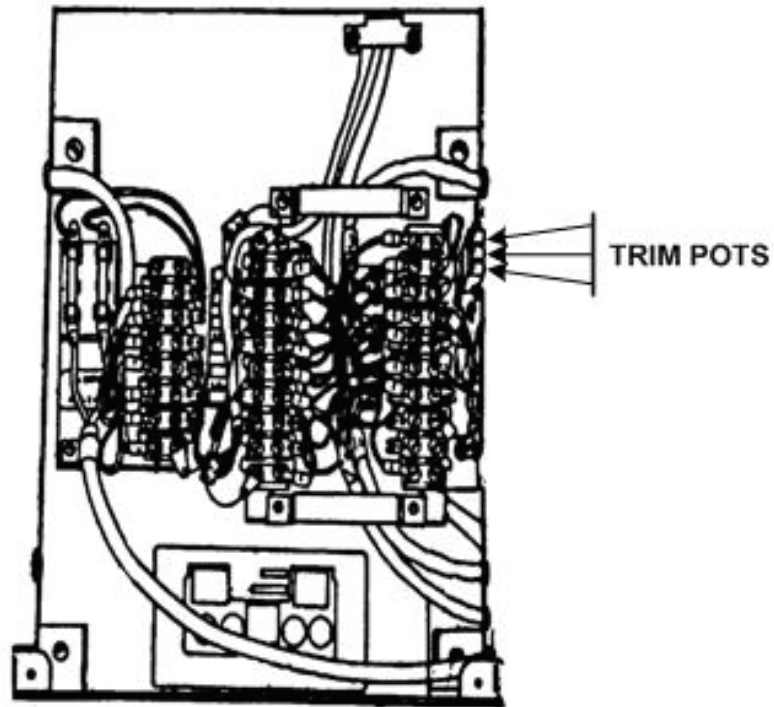

Figure 3. Trim pot location.

- (7) After matching errors are obtained, apply loads to any cell in 3000 pound increments.
- (8) Remove TI panel.
- (9) Remove cover of board and component assembly (fig. 4).
- (10) Adjust resistor SPOOL FINGERS (fig. 4) for best linearity (R).

**NOTE**

When sliding these fingers, each cell error will shift a similar value. If cell with highest error value at an applied load is being adjusted to a lower value, cell with lowest error value cannot be allowed to drop below the tolerance limits.

- (11) Replace board and component cover and TI panel.
- (12) Repeat 8 a above.



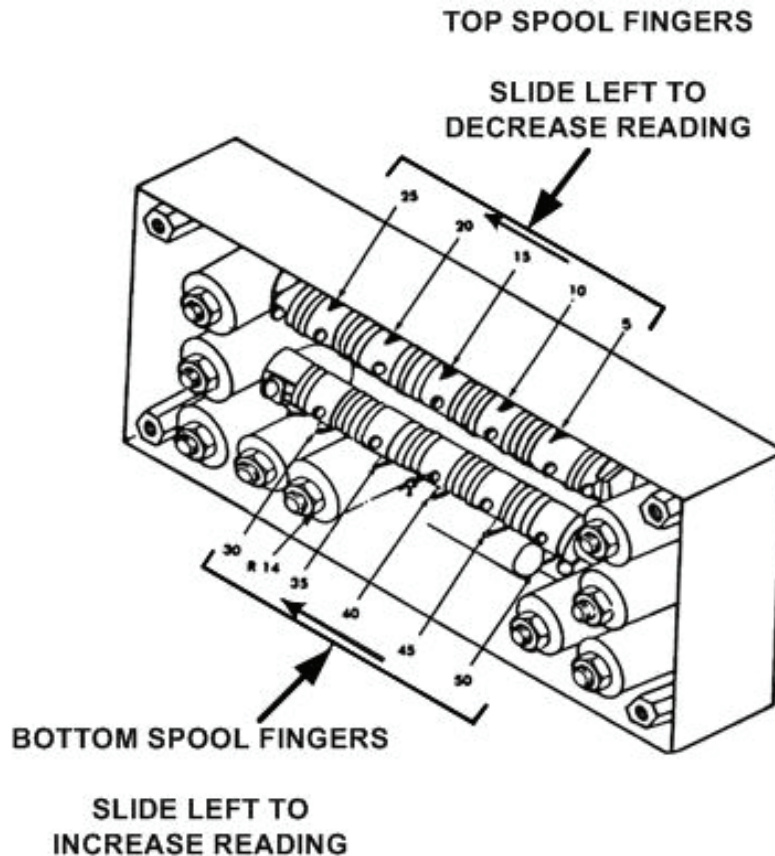

Figure 4. Calibration arrangement.

(13) Remove the eight (8) larger screws from the edge around the front panel and remove the indicator from the case.

(14) Turn on the channel to be zeroed, all others off.

(15) Center the front panel **ZERO** knob by turning fully clockwise, then five (5) turns counterclockwise.

(16) Adjust the coarse zero pot located on the upper right rear of the indicator for a zero reading on the digital indicator.

(17) Reassemble and apply 15,000 pounds of force. If display does not read correct weight, adjust span pot in the center of the front panel for the cell that is under test to the correct indication. Pots may be covered with labels. Repeat 8 a above.

## 9. System Calibration Alternate Technique (Reference)

### a. Performance Check

(1) Set voltage selector switch on TI to position which corresponds to power source being used. Connect TI to power source.

(2) If ac is used, check voltage as follows:

- (a) Set power switch to 115 V 60~.
- (b) Operate **BATTERY VOLTAGE** switch on indicator panel of TI and adjust **AC VOLTAGE ADJUST** control until pointer of balance meter indicates in green area of milliammeter scale.
- (3) If 24 V dc is used as power source, operate **BATTERY VOLTAGE** switch and check polarity. If meter indication is in yellow area, change leads and operate **BATTERY VOLTAGE** switch again. If meter indication is in red area, battery voltage is either too high or too low and should be replaced.
- (4) Allow sufficient time for equipment to warm-up and stabilize.
- (5) Set up equipment as shown in figure 5. Use load cell No. 4 with compatible spherical button and TI cell No. 1 (red).

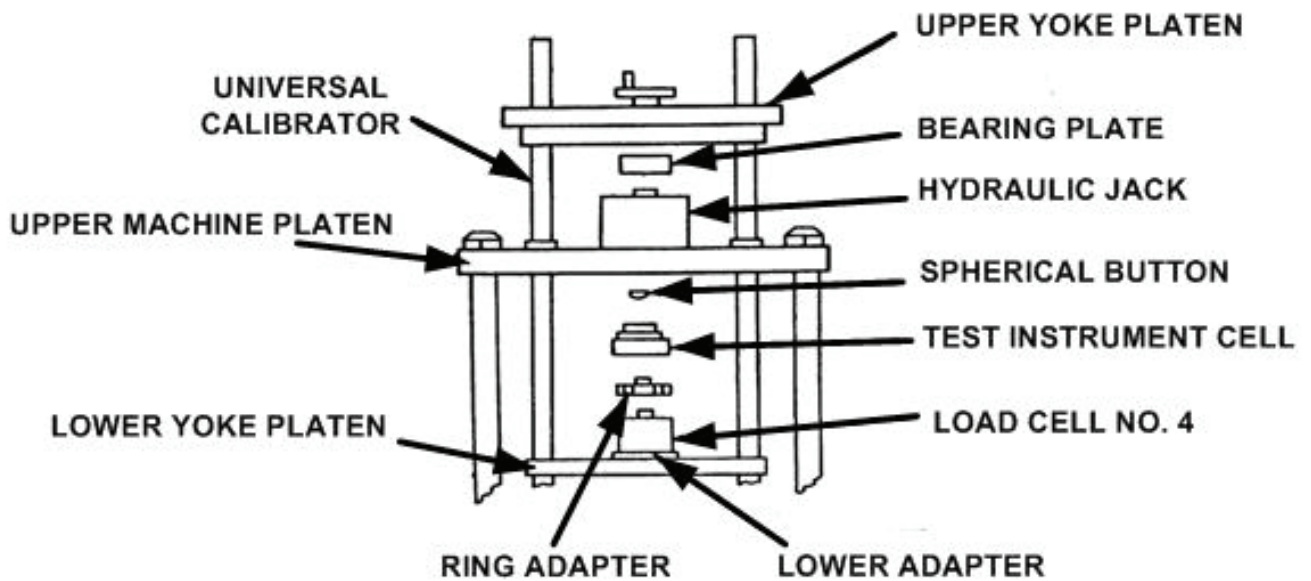

Figure 5. System equipment setup - alternate technique (reference).

- (6) Bolt **LOWER ADAPTER** (fig. 5) to bottom of load cell No. 4. Mount on **LOWER YOKE PLATEN** (fig. 5).

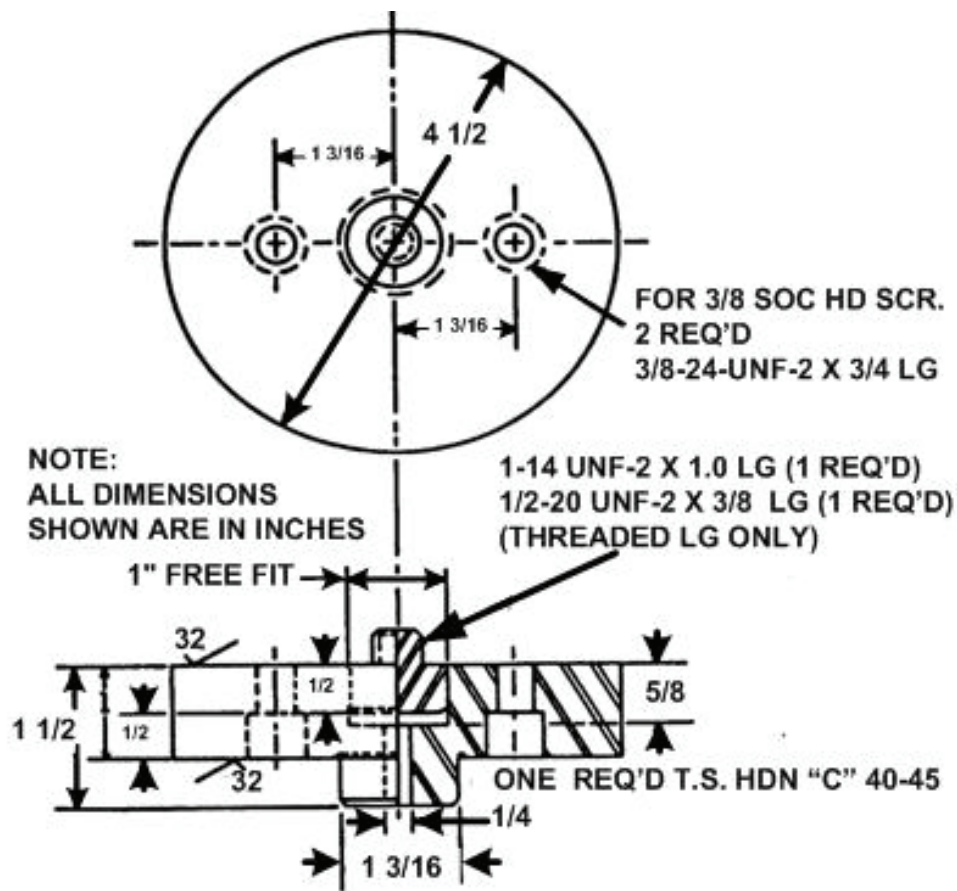

Figure 6. Lower adapter.

- (7) Connect all three TI cells to TI indicator using proper cables (color coded).

**NOTE**

Do not disconnect TI cells from TI indicator except as necessary when making setups.

- (8) Connect cable to appropriate connectors on load cell No. 4 and load cell indicator.
- (9) Connect load cell indicator to a 115 V ac power source. Energize all equipment and allow unit to warm-up for 15 minutes.
- (10) Zero set load cell in no load condition.
- (11) Set TI **CELL BALANCE** switch to **ON** and **CELL SELECTOR** switch to **1**.
- (12) Turn TI **WEIGHT** dial and **INITIAL LOAD** switch to **0**.
- (13) Adjust TI **ZERO SET** control No. 1 for balance in no load condition.
- (14) Set TI **INITIAL LOAD** switch to **45** and **WEIGHT** dial to 5000 pounds.
- (15) Exercise load cell No. 4 and TI cell by applying pressure until TI meter pointer indicates **NULL**. Release pressure, and then apply pressure to full scale of TI three times.

**CAUTION**

Avoid overshooting 50,000 pounds pressure; approach **NULL** indication slowly.

(16) Make sure that lower adapter (fig. 5) is tightly attached to load cell No. 4 after pressure is released.

(17) Set **TI INITIAL LOAD** switch to **10** and **WEIGHT** dial to 5000 pounds.

(18) Apply load for null condition as indicated on TI balance meter. If indication on load cell is not between 14,962.5 and 15,037.5 pounds, perform **b** below.

**NOTE**

Do not overshoot null condition. If this occurs, release pressure and repeat **a** (18) above.

(19) Set **INITIAL LOAD** switch to **15** and **WEIGHT** dial to **0**.

(20) Repeat (18) above.

(21) Perform check at 5000 pound increments to high limit of cell under test. Indication on TI and load cell indicator will be within  $\pm 25$  pounds or  $\pm 0.25$  percent whichever is greater.

(22) Release pressure from system and remove TI cell No. 1 from setup.

(23) Repeat (10) through (22) above for each of the remaining two cells.

(24) Substitute load cell No. 3 for cell No. 4 in setup. Change adapters as required.

(25) Set **TI INITIAL LOAD** switch to **10** and **WEIGHT** dial to **0**.

(26) Exercise load cell several times by applying pressure until TI indicates null, and then release pressure.

**CAUTION**

Do not overload load cell.

(27) Repeat technique of (17) through (23) above, checking each TI cell from 1000 to 10,000 pounds in 1000 pound increments. Indication on TI and load cell indicator will be within  $\pm 25$  pounds.

(28) Substitute load cell No. 2 for cell No. 3 in setup. Change adapters as required.

(29) Set **TI INITIAL LOAD** switch to **0** and **WEIGHT** dial to 1000.

(30) Exercise load cell several times by applying pressure until TI indicates null, and then release pressure.

(31) Repeat technique of (17) through (23) above, checking each TI cell from 500 to 1000 pounds in 50 pound increments. Indication on TI and load cell indicator will be within  $\pm 25$  pounds.

**NOTE**

If calibration report for load cell does not provide readings for 50 and 200 pound loads, begin at 350 pounds.

**b. Adjustments**

- (1) Connect multimeter to gray (+) and violet (-) terminals of TI power supply switch.
- (2) Adjust R201 (fig. 2) for 24 V dc as indicated on multimeter.
- (3) Zero adjust TI in a no load condition.
- (4) Apply a known load to system, preferably 50,000 pounds.
- (5) Set TI **INITIAL LOAD** switch and **WEIGHT** dial of indicator to amount of load applied.
- (6) Adjust appropriate TRIM POT (span) (fig. 3) until indicator pointer of TI indicates a null. A trim pot is provided for each cell. These adjustments are located next to the terminal strip of the indicator amplifier assembly (R).

**NOTE**

In older models of the TI, no span adjustment can be made. Resistors of the proper value must be installed. If this becomes necessary, install adjustable resistors of the proper nominal value and repeat **b** (3) through (6) above.

- (7) After matching errors are obtained, apply loads to any cell in 5000 pound increments.
- (8) Remove TI panel.
- (9) Remove cover of board and component assembly (fig. 4) for best linearity.
- (10) Adjust resistor SPOOL FINGERS (fig. 4) (R).

**NOTE**

When sliding these fingers, each cell error will shift a similar value. If cell with highest error value at an applied load is being adjusted to a lower value, cell with lowest error value cannot be allowed to drop below the tolerance limits.

- (11) Replace board and component cover and TI panel.
- (12) Repeat performance test.

**10. Final Procedure**

- a.** Deenergize and disconnect all equipment.
- b.** Annotate and affix DA label/form in accordance with TB 750-25.

**SECTION IV  
CALIBRATION PROCESS FOR  
REVERE, MODELS C55800-3-50, 155800-00, 155800-01, AND 155800-03**

**11. Preliminary Instructions**

a. The instructions outlined in paragraphs 11 and 12 are preparatory to the calibration process. Personnel should become familiar with the bulletin before beginning the calibration.

b. Items of equipment used in this procedure are referenced within the text by common name as listed in table 2.

c. Unless otherwise specified, verify the result of each test and, whenever the test requirement is not met, take corrective action before continuing with the calibration. Adjustments required to calibration the TI are included in this procedure. Additional maintenance information is contained in the manufacturer's manual for this.

d. Unless otherwise specified, all controls and control settings refer to the TI.

**NOTE**

Units having transfer equipment will use the transfer technique. If calibration above 15,000 pounds is required, the reference technique will be utilized. If transfer equipment is not available, use reference technique pending availability of transfer equipment. All TI's certified by transfer technique will have a DA Label 163 affixed stating that each cell was certified to 15,000 pounds only. When transfer technique is used and TI cannot be adjusted to within tolerance, TI will be forwarded for reference calibration and repair.

**12. Equipment Setup**

**WARNING**

HIGH VOLTAGE is used or exposed during the performance of this calibration. DEATH ON CONTACT may result if personnel fail to observe safety precautions. REDUCE OUTPUT(S) to minimum after each step within the performance check where applicable.

a. Connect three TI cell cables to proper cell observing and matching proper color coding.

b. Connect TI indicator to a 115 V ac power source.

c. Position controls as indicated in (1) through (5) below:

(1) Set **POWER** switch to 115 V position and allow 15 minutes for warm-up.

- (2) Set **LOAD INDICATOR-BATTERY CHECK** switch to **LOAD INDICATOR** position.
- (3) Set **CELL SELECTOR** switch to **CELL1**.
- (4) Set **POUNDS** thumbwheels to **0000**.
- (5) Adjust **ZERO SET** control for null indication on TI.

**NOTE**

**BATTERY CHECK** position of the **LOAD INDICATOR-BATTERY CHECK** switch is used only when TI is connected to a 24 V dc source. The null meter must indicate within green area on scale (22 to 28 V dc) for proper operation.

**NOTE**

When using battery power operation, assure correct voltage is maintained. Unless correct voltage is maintained, improper indications may result.

### 13. Load Test

#### a. Performance Check

- (1) Setup equipment as shown in figure 1 using load cell No. 1 and TI cell No. 1.
- (2) Connect cable to appropriate connectors on load cell No. 1 and load cell indicator.
- (3) Connect load cell indicator to a 115 V ac power source. Energize all equipment and allow unit to warm-up for 15 minutes.
- (4) Set **CELL SELECTOR** switch to **CELL 1** position and verify a null indication.
- (5) Exercise load cell No. 1 and TI cell as described in (a) through (f) below:
  - (a) Set **POUNDS** thumbwheel to **2000** (15,000 pounds, using load cell No. 3).
  - (b) Apply force slowly to load cell and TI cell to obtain approximately 2000 pounds (15,000 pounds, using load cell No. 3).
  - (c) Release force to obtain a zero indication on indicators.
  - (d) Repeat (a) and (b) above two more times.
  - (e) Set **POUNDS** thumbwheel to **0000** and verify that TI indicator indicates **0**.
  - (f) Readjust load cell indicator **BRIDGE-ZERO**, if necessary, to obtain a reading of 0000.
- (6) Rotate the **POUNDS** thumbwheel to obtain an indication of **200**.
- (7) Apply force from hydraulic force H frame for null indication on TI **NULL** meter. If load cell indicator does not indicate between 175 and 225, proceed to (9) below.
- (8) Repeat technique of (6) and (7) above for **POUNDS** thumbwheel settings listed in table 4. If load cell indicator does not indicate within limits specified, perform **b** (1) through (3) below.

Table 4. Load Cell Accuracy

POUNDS thumbwheel settings	Load call indicator indications (lbs)	
	Min	Max
300	275	325
400	375	425
500	475	525
600	575	625
700	675	725
800	775	825
900	875	925
1000	975	1025
2000	1975	2025
3000 <sup>1</sup>	2975	3025
4000	3975	4025
5000	4975	5025
6000	5975	6025
7000	6975	7025
8000	7975	8025
9000	8975	9025
10,000	9975	10,025
15,000	14,962.5	15,037.5

<sup>1</sup>Replace load cell No. 1 with load cell No. 3 and repeat technique of 13 a (5) through (7) above.

(9) Repeat (1) and (5) through (8) above for the remaining two TI cells. Perform **b** (4) for TI cell No. 2 and **b** (5) for TI cell No. 3, if adjustments are required.

**NOTE**

If a linearity error occurs at any setting (if the indicator is low or high on all three TI cells), perform the linearity adjustments specified in **b** (6) below.

**b. Adjustments**

**NOTE**

Adjustments in (1) through (3) below are for each TI cell and are to be performed at 15,000 pounds with load cell No. 3 installed. If an indication within limits specified cannot be obtained, adjust R29 SPAN (fig. 7). R29 SPAN affects all three TI cell adjustments. If R29 SPAN is adjusted, repeat steps (1) through (3) below until no further adjustments are necessary.

(1) Loosen six screws on front of TI and remove front cover.



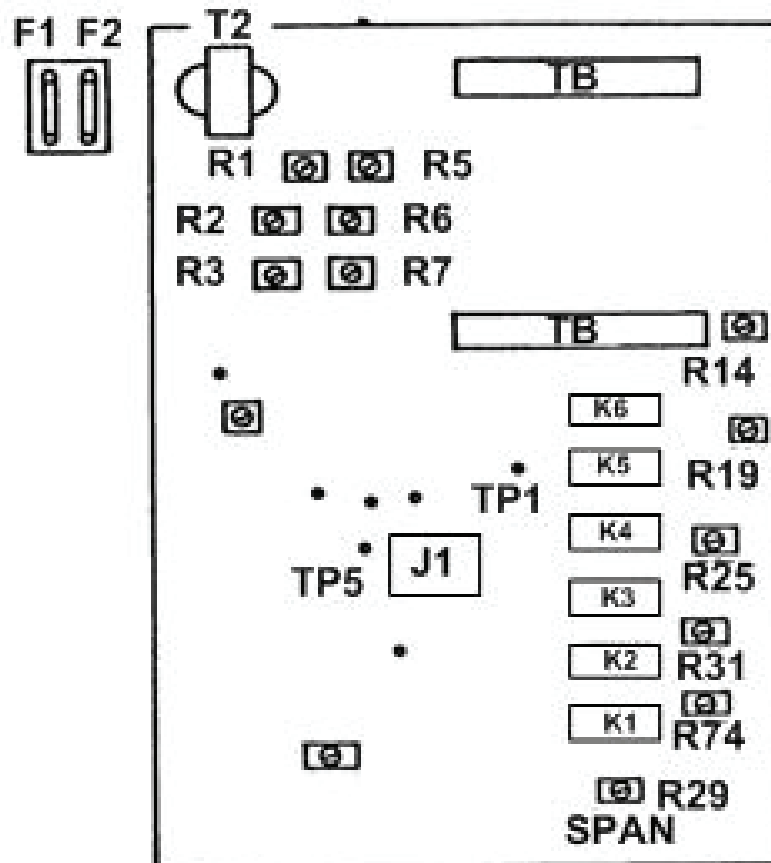

Figure 7. Adjustment locations.

- (2) Rotate **POUNDS** thumbwheel to **15,000** and apply force for **NULL** indication.
- (3) Adjust R5 (fig. 7) for an indication within limits specified.
- (4) Adjust R6 (fig. 7) for an indication within the limits specified. (R)
- (5) Adjust R7 (fig. 7) for an indication within the limits specified. (R)
- (6) Linearity adjustments:
  - (a) Apply a 10,000 pound load to cells, set **POUNDS** thumbwheel to **10,000** and adjust R31 (fig. 7) for null indication (R).
  - (b) Apply a 20,000 pound load to cells, set **POUNDS** thumbwheel to **20,000** and adjust R25 (fig. 7) for null indication (R).

#### 14. Zero and Phase Check Alternate Technique (Reference)

##### a. Performance Check

##### NOTE

Ensure that there is no load on load cells.

- (1) Verify null indication on TI null meter by adjusting **ZERO** control as required.

**NOTE**

Do not use an attenuator probe in (2) below.

- (2) Connect oscilloscope between TP1 (red lead) and TP5 (black lead) (fig. 7). If indication on oscilloscope is not less than 1.5 V p-p, perform **b (1)** below.
- (3) Set **CELL SELECTOR** switch to **CELL 2** position.
- (4) Adjust **ZERO** control for null indication on TI null meter. If indication on oscilloscope is not less than 1.5 V p-p, perform **b (2)** below.
- (5) Set **CELL SELECTOR** switch to **CELL 3** position.
- (6) Adjust **ZERO** control for null indication on TI null meter. If indication on oscilloscope is not less than 1.5 V p-p, perform **b (3)** below.

**b. Adjustments**

- (1) Adjust R1 (fig. 7) for minimum waveform amplitude on oscilloscope. **ZERO** control (front panel) must be adjusted simultaneously to keep the meter at 0 indication.
- (2) Adjust R2 (fig. 7) for minimum waveform amplitude on oscilloscope. **ZERO** control (front panel) must be adjusted simultaneously to keep the meter at 0 indication (R).
- (3) Adjust R3 (fig. 7) for minimum waveform amplitude on oscilloscope. **ZERO** control (front panel) must be adjusted simultaneously to keep the meter at 0 indication (R).

**15. Load Test Alternate Technique (Reference)**

**a. Performance Check**

- (1) Place TI cell No. 1 in lower adapter (if required) as fabricated in figure 6. Place TI cell No. 1 in universal calibrator (force) with load cell No. 4.
- (2) Place **CELL SELECTOR** to **CELL 1** position and verify a null indication.
- (3) Using universal calibrator (force), apply a load of 50,000 pounds to TI cell. Rotate **POUNDS** thumbwheels to obtain a null indication on TI null meter. The procedure for adjusting **POUNDS** thumbwheel is as follows:
  - (a) Adjust **MSD** (left thumbwheel) until meter pointer swings across null indication.
  - (b) Move **MSD** back one digit so that meter pointer swings back across null.
  - (c) Repeat (b) above with second and third thumbwheel.
  - (d) Adjust final thumbwheel for an exact null indication.
  - (e) Read weight directly from **POUNDS** thumbwheel, 50,000  $\pm$ 125 pounds.
- (4) Exercise load cell No. 4 and TI cell to full capacity three times.
- (5) If **POUNDS** thumbwheel indication is not within limits, perform **b (1)** below.
- (6) Decrease universal calibrator (force) setting to 10,000 pound indication on TI. Check cell indication at each step; apply force at 10,000, 15,000, 20,000, 30,000, 40,000, and 50,000 pounds. Indications on TI and load cell indicators will be within  $\pm$ 25 pounds for 10,000 pounds and  $\pm$ 0.25 percent from 15,000 to 50,000 pounds.

(7) Repeat (1) through (6) above for each of the remaining two TI cells. Perform **b** (2) below for TI cell No. 2 and **b** (3) below for TI cell No. 3, if adjustments are required.

**NOTE**

If a linearity error occurs at any setting (if indicator is low or high on all three TI cells), perform linearity adjustments specified in **b** (4) below.

(8) Substitute load cell No. 3 for load cell No. 4 in setup.

(9) Exercise load cell No. 3 to full capacity three times.

(10) Check TI cell from 2000 to 10,000 pounds in 1000 pound increments. TI indication will be within  $\pm 25$  pounds of load cell indicator indication.

(11) Repeat (10) above for each of the remaining two TI cells.

(12) Substitute load cell No. 2 for load cell in No. 3 in setup. Exercise load cell No. 2 to full capacity three times.

(13) Check TI cell from 200 to 2000 pounds in 200 pound increments. TI indicator indication will be within  $\pm 25$  pounds of load cell indicator indication.

(14) Repeat (13) above for each of the remaining two TI cells.

**b. Adjustments**

**NOTE**

Adjustments in (1) through (3) below are for each TI cell and are to be performed at 50,000 pounds with load cell No. 4 installed. If an indication within limits specified cannot be obtained, adjust R29 SPAN (fig. 7). R29 SPAN affects all three TI cell adjustments. If R29 SPAN is adjusted, repeat (1) through (3) below until no further adjustments are necessary.

(1) Adjust R5 (fig. 7) for an indication within limits specified (R).

(2) Adjust R6 (fig. 7) for an indication within limits specified (R).

(3) Adjust R7 (fig. 7) for an indication within limits specified (R).

(4) Linearity adjustments:

(a) Apply a 10,000 pound load to cells, set **POUNDS** thumbwheel to **10,000** and R31 (fig. 7) for a null indication (R).

(b) Apply a 20,000 pound load to cells, set **POUNDS** thumbwheel to **20,000** and adjust R25 (fig. 7) for a null indication (R).

(c) Apply a 30,000 pound load to cells, set **POUNDS** thumbwheel to **30,000** and adjust R19 (fig. 7) for a null indication (R).

(d) Apply a 40,000 pound load to cells, set **POUNDS** thumbwheel to **40,000** and adjust R14 (fig. 7) for a null indication (R).

**16. Final Procedure**

- a.** Deenergize and disconnect all equipment.
- b.** Annotate and affix DA label/form in accordance with TB 750-25.

By Order of the Secretary of the Army:

Official:

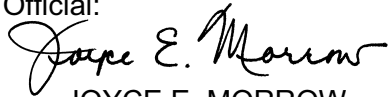

JOYCE E. MORROW  
*Administrative Assistant to the  
Secretary of the Army*

GEORGE W. CASEY, JR.  
*General, United States Army  
Chief of Staff*

0819902

Distribution:

To be distributed in accordance with the initial distribution number (IDN) 342301, requirements for calibration procedure TB 9-6670-258-24.



## ***These are the instructions for sending an electronic 2028***

The following format must be used if submitting an electronic 2028. The subject line must be exactly the same and all fields must be included; however only the following fields are mandatory: 1, 3, 4, 5, 6, 7, 8, 9, 10, 13, 15, 16, 17, and 27.

From: "Whomever" [whomever@wherever.army.mil](mailto:whomever@wherever.army.mil)

To: 2028@redstone.army.mil

Subject: DA Form 2028

1       ***From: Joe Smith***  
2       ***Unit: home***  
3       ***Address: 4300 Park***  
4       ***City: Hometown***  
5       ***St: MO***  
6       ***Zip: 77777***  
7       ***Date Sent: 19--OCT--93***  
8       ***Pub no: 55--2840--229--23***  
9       ***Pub Title: TM***  
10       ***Publication Date: 04--JUL--85***  
11       ***Change Number: 7***  
12       ***Submitter Rank: MSG***  
13       ***Submitter FName: Joe***  
14       ***Submitter MName: T***  
15       ***Submitter LName: Smith***  
16       ***Submitter Phone: 123--123--1234***  
17       ***Problem: 1***  
18       ***Page: 2***  
19       ***Paragraph: 3***  
20       ***Line: 4***  
21       ***NSN: 5***  
22       ***Reference: 6***  
23       ***Figure: 7***  
24       ***Table: 8***  
25       ***Item: 9***  
26       ***Total: 123***

27       ***Text:***

This is the text for the problem below line 27.







